

## The "Slingshot" Antenna for 2 Meters

Re-edited by N4UJW from an original article by David Younker  
**KA8OGD** (callsign no longer active)  
73 Magazine April 1989

While recently going thru some of my old ham radio magazines, I ran across this neat, inexpensive and easy to build antenna project for 2 meters. I have not seen it on the internet so here it is for you to try!

I personally have not tried this antenna but it should work fine if you follow the very simple directions!

It can be built as is for 2 meters, or you can try it on other bands or frequencies with the formulas provided by me below.

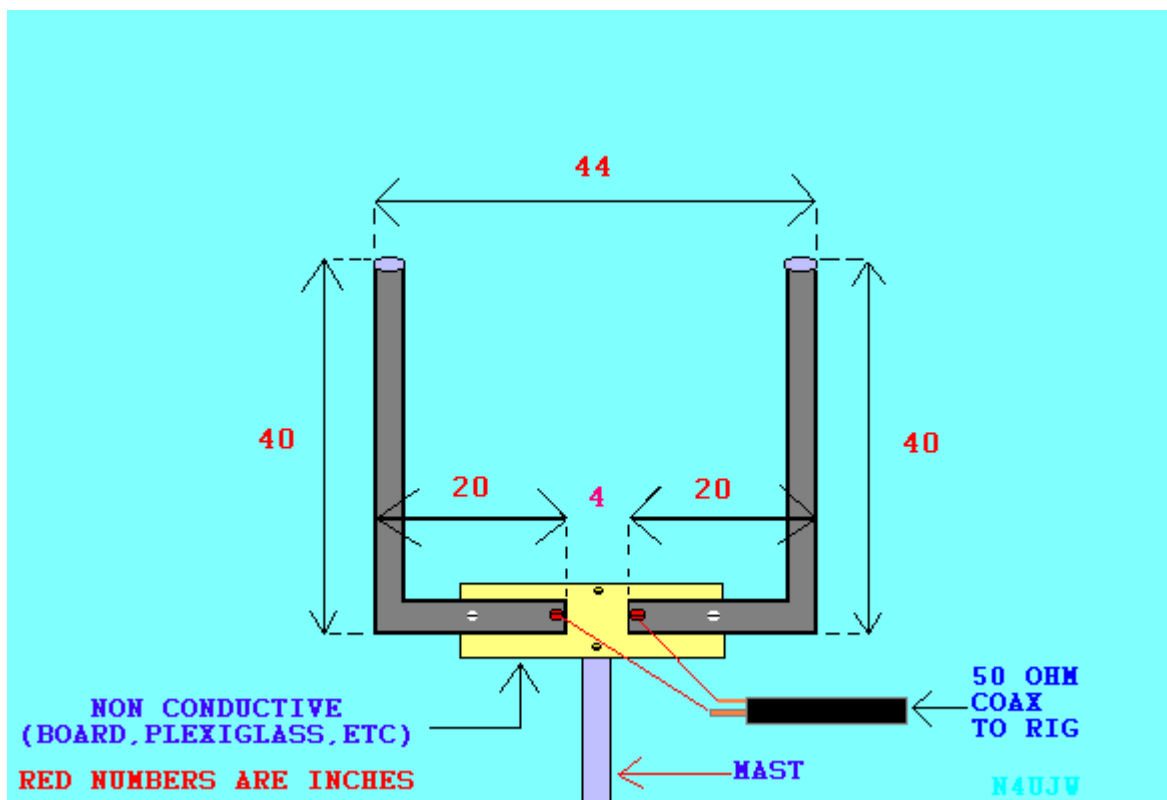

THE SLINGSHOT ANTENNA  
NOT DRAWN TO SCALE

Please note in drawing that elements are bent 90 degrees. Make your bends as needed depending on material used for elements. If you use copper tubing, a 90 degree elbow on each should work fine. If you are comfortable with bending, great, if not, get the hardware store to do it for you!

The completed antenna is bi-directional with a rough figure 8 pattern and is composed of 2, 3/4 wavelength sections of electrical conduit bent and cut to the lengths in the drawing and supported as shown on any type of insulating material attached to the mast with whatever arrangement of bolts, nuts, clamps, etc.

You should note that the bottom (horizontal element portion) is 1/4 wavelength long and the top (vertical element section) is 1/2 wavelength long.

The element mounting plate (in yellow in the drawing) can be plexiglass, painted wood or whatever you happen to have that is **NON CONDUCTIVE**. You can use copper or aluminum for the active 3/4 wave elements, but aluminum would be preferred due to less weight.

Although electrical conduit comes in various sizes, the size was not stated in the original article but I would suggest 1/2 inch or larger in diameter. (The larger, the greater the bandwidth.)

The total length of each element is 60 inches + - and they are attached about 4 inches apart on the mounting plate with enough bolts and nuts as needed.

The coax attachment points are in red on the picture, and I would suggest that you use spade lugs on the ends of the coax to attach it to the bottom end of each element (the ends nearest the bend) with bolts, nuts and lock washers all the way thru the element and plate. There must be a good electrical connection between the coax center conductor and shield braid and each element. Keep the connections lengths from the end of the coax as short as possible. They become part of the radiating element lengths.

It does not matter which conductor from the coax is attached to which element.

**SEAL ALL CONNECTIONS AND THE END OF THE COAX!**

When attaching the elements to the mounting plate, drill enough holes all the way thru the elements and plate for good mechanical stability and attach with bolts and nuts. The elements and coax connections must not touch the support mast at any point if the mast is made of metal of any kind! You could use a pvc pipe or

length of lumber of the required length instead of metal to get the antenna up as high as possible and a half wave or more is preferred!

"This design, untrimmed, up a half wave, presented an SWR of 1.5:1 across the top 2 MHz of the band (146-148mhz)" .....KA8OGD

A note or two more about experimenting with this antenna:  
MAXIMUM SIGNAL IS OFF BOTH ENDS (TO THE RIGHT AND LEFT AS DRAWN NOT BROADSIDE. Point the boom at your target!)  
ANTENNA SHOULD BE ROTATED IN DIRECTION NEEDED!

The formulas for calculating the lengths for this project seem to be approximately the following.

There is a more complicated formula first and then a simple version....take your choice...they both yeild the same result:

$11808/\text{freqmhz} = 1 \text{ wavelength in inches}$   
 $11808/147.00\text{Mhz} = 80.3 \text{ inches (using 147.00Mhz)}$   
 $3/4 \text{ wavelength} = .75 \times 80.3 = 60.2 \text{ inches}$

**Simple version formulas:**

$8856 / \text{freqmhz} = 3/4 \text{ wavelength section in inches (total element length)}$

$5904 / \text{freqmhz} = 1/2 \text{ wavelength section in inches}$

$2952 / \text{freqmhz} = 1/4 \text{ wavelength section in inches}$

**Lets do a calculation for 144.200Mhz ssb using the more complicated version formula:**

$11808/144.200 = 81.88 \text{ inches}$

$3/4 \text{ wavelength} = .75 \times 81.88 = 61.4 \text{ inches total element length per side}$

$1/4 \text{ wavelength would be} = 81.88 / 4 = 20.47\text{inches or } 1/3 \text{ of } 61.4 \text{ inches. (The vertical section takes } 2/3\text{rds of the total length of one side of the antenna element)}$

The 90 degree bend will be at the 1/4 wave point on the total length.

**Footnote to construction: It is advisable to add about 5 or 6 turns of coax at the base of the antenna as an air choke to help keep rf**

**off the feedline. Some builder do this....some don't.**

According to the article, 15 meters is about as low in frequency as it can be used before it becomes very difficult to keep it up due to size and weight! (one element would be about 34.5 feet long according to my Texas Instruments model TI-7140 handheld calculator and the above formulas!) HI!

### **MODIFICATIONS, COMMENTS AND UPDATES!**

Experimentation performed by LA2PJ of Norway taken from his email: (January 23, 2003)

Tonight I have tried a construction from your webpages,  
The Slingshot Antenna.

Just soldered two wires to the end of a short length of coax and pinned it to the wall in my shack with small needles to get the correct shape.

**The results were amazing!** The direction of the wall is in the right direction to a distant repeater here on the west coast of Norway. Using an Alinco handheld with approx 1W, I was able to work through the repeater with full quieting. The distance is 94 kilometers (approx. 55 miles. The reports indicated that they could not notice the difference when I switched between this indoor antenna and a Diamond X-510 vertical on the roof. The SWR was 1.4:1 at 144MHz rising to 1.7:1 at 146 MHz, indicating that the antenna is a bit long.

But then the elements are made of 1mm stranded copper wire. Am thinking of a way to produce the antenna to be used outdoors.

If your offer is still valid, I would like to present this antenna in Norwegian at our web site.

Best 73's  
Egil - LA2PJ

(I said yes to his request for adding the project to his site in Norway. Stay tuned here for the link when he gets it up and running for our fellow Norwegian Ham friends to enjoy.)

**Editors note:** Egil, LA2PJ, is the former Webmaster for the NRRL, the Norway counterpart to our ARRL!

**Update from KC2GOA:** The two meter slingshot works now that I made some changes. I had to change the spacing between the two elements to 1/2 inch and cut the short lengths to 19 1/4 inches and the long ones down to 39 1/4 inches and I came up with a 1.2 swr at 146.000mhz. 73's KC2GOA.....

**[Editors note:** The diameter of the elements and the spacing at the center insulator will play an important part in getting the antenna to resonate at your frequency of operation for lowest SWR. Some experimentation may be needed with your particular construction techniques!]

**More updates:** January 2004  
440mhz scaled version by N9YBP [CLICK HERE](#)

**From the editor:** I hope you try this antenna project as is and if you are pleased with the results, please let me know, and if you have tried any modifications to it and they worked a lot better in performance, please [email me](#) with them. I will be glad to add them to this project with full credit going to you!

EXPERIMENT! EXPERIMENT! EXPERIMENT!  
(See latest experiments with this antenna and input from builders next below.)

**MORE MODS FEBRUARY, 2005 BY ROY:**

I constructed this antenna as per KC2GOA's latest dimensions. However I added an SO 239 connector between the two elements for direct connection with coax with a PL259 connector. See drawing below: For the antenna itself. I used the 1/2" copper tubing AS STATED ABOVE, but for connecting the two sides together, I used a 12" piece of 1/2" PVC which the copper tubing fit snugly inside of, and attached an SO 239 connector in the middle.

I mounted the 239 connector on the PVC with a self tapping screw into the GAP between the antenna sides.  
I then bolted thru both PVC and copper tubing with brass machine screws and nuts to secure the tubing to the PVC.

### N9AGT SLINGSHOT MODIFICATION

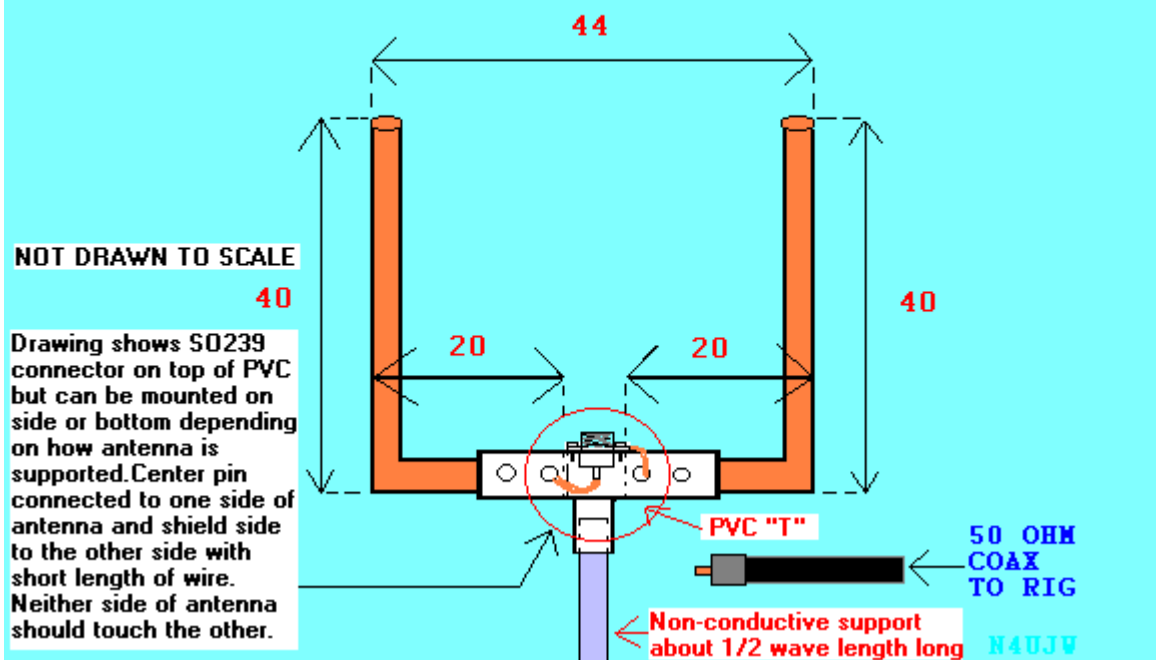

To make the connections to the 239 connector, I bore oversized holes into the PVC so that the screw head and nuts would contact the copper tubing. I bought the brass screws long enough - 1 1/4" - so that I could put two nuts on them; one to hold it to the tubing and the other to act as a lug to connect a short piece of bare #14 copper wire to. I then soldered the other end to the 239 connector. I repeated that for the other side. This makes it a neat and clean antenna.

I hung my antenna from the rafters in the attic - **upside down!**

I use it as my east/west antenna as I already had built the '[Hentenna](#)' antenna that you have on your website for the north/south coverage!

They both work great! If someone wanted to mount this antenna right side up, they would need to put a PVC tee between the sides and point it downward! I used 12" of PVC pipe, but you could use it much longer and add more screws for better support in the vertical position!

**73 N9AGT, Roy.**

**Editors note:** Great work Roy! I'm sure there are other ways to attach the coax to the antenna.....

an MFJ ANTENNA ANALYZER would help in tuning the antenna, but use what you have.....

keep experimenting and have fun!.....N4UJW

**440 mhz Slingshot Scaled version**