

### VHF/UHF Dualband vertical antenna

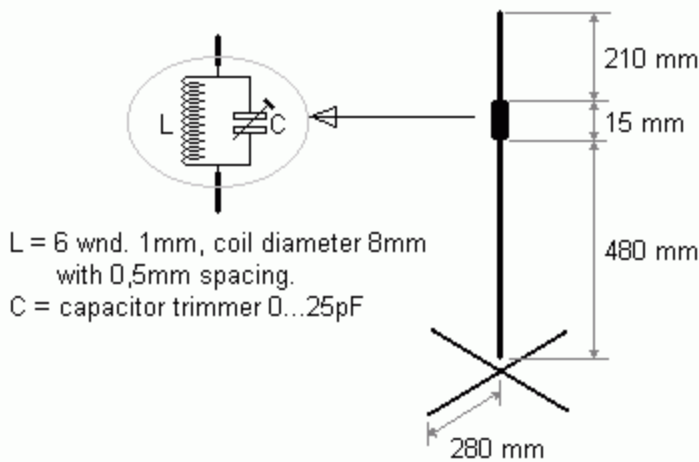

L = 6 wnd. 1mm, coil diameter 8mm  
with 0,5mm spacing.

C = capacitor trimmer 0...25pF

I used for this antenna aluminum tubing of 10mm diameter. Or you can use a brass rod of about 7mm diameter. The top one is a strong copper (brass) wire of 5 to 7 mm diameter soldered directly to the coil and mounted to the PVC isolator to give a strong construction. Because the top wire is only 21 cm long so this will be strong enough in a 6 or 7 mm copper wire. The antenna has a unity gain in the 2 meter band and about 5dB in the UHF band. SWR will be in both bands within 1.5. The dualband antenna is a quarter wave on 2 meters and a full wave on 70 cm. Tuning of the antenna is needed! This part must be done very carefully. You must tune the capacitor until you get a 1:1 SWR on 145.000 MHz. Again you need to tune it very carefully because the coil and the capacitor must be tuned until it will block the 2 meter band (parallel resonance). UHF does'nt need to be tuned. In some cases you can improve the SWR on UHF by cutting the top piece if needed. I incapsuled the coil and variable capacitor in a PVC tube of 12mm with a small hole to regulate the variable capacitor and then placed the top and bottom 10mm tube in the PVC tube, screwing the parts throo the PVC tube. With some silicones you can make the construction water-proof. If are using copper tubes then it should be no problem to solder the parts. This allows for 'no maintenance' after years of use in all kinds of weather. The center of the coax is connected to the vertical tube and the radials (4 x 28 cm) are all connected to the shield of the coax.